

GUJARAT TECHNOLOGICAL UNIVERSITY**BE - SEMESTER– VIII (New) EXAMINATION – WINTER 2019****Subject Code: 2182004****Date: 02/12/2019****Subject Name: Design of Mechanisms - II****Time: 02:30 PM TO 05:00 PM****Total Marks: 70****Instructions:**

1. Attempt all questions.
2. Make suitable assumptions wherever necessary.
3. Figures to the right indicate full marks.
4. Use of PSG design data book is permitted

- Q:1 (a)** Answer the following questions **03**
1. Which of the following stresses are associated with the design of pins in bushed pin type flexible coupling

(a) Torsional shear and bending stress	(b) Crushing and bending stress
(c) Bending, bearing stress and transverse shear	(d) Shear and crushing stress
 2. The design calculations for members subjected to fluctuate loading with the same factor of safety yield the most conservative estimate when using

(a) Gerber relation	(b) Soderberg relation
(c) Goodman relation	(d) Modified Goodman relation
 3. A wire rope is designated as 6×19 standard hoisting. The number 6 \times 19 represent

(a) Number of strands \times number of wires in each strands	(b) Diameter in millimeter \times length in meter
(c) Number of wires in each strands \times number of strands	(d) Wire diameter \times sheave diameter
- (b)** Answer the following questions **04**
- 1 For safe design of spur gear

(a) Wear strength < Dynamic load	(b) Wear strength > Dynamic load
(c) Beam strength > Dynamic load	(d) Both (b) and (c)
 - 2 In the assembly design of shaft, pulley and key, the weakest member is:

(a) Shaft	(b) Pulley
(c) Key	(d) None
 - 3 The bearing characteristic number in hydrodynamic bearing depends on

(a) Length, width and load	(b) Length, width and speed
(c) Viscosity, speed and load	(d) Viscosity, speed and bearing pressure
 - 4 The life of a ball bearing is inversely proportional to

(a) (Load) ^{1/3}	(b) (Load) ³
(c) (Load) ^{1/2}	(d) None of the above
- (c)** Design a rigid flange coupling to transmit a torque of 250 N-m between two coaxial shafts. The shaft is made of alloy steel, flanges out of cast iron and bolts out of steel. Four bolts are used to couple the flanges. The shafts are keyed to the flange hub. The permissible stresses are given below:

Shear stress on shaft =100 MPa

Bearing or crushing stress on shaft =250 MPa

Shear stress on keys =100 MPa

Crushing stress on keys =250 MPa

Shearing stress on cast iron =15 MPa

Shear stress on bolts =100 MPa

After designing the various elements, make a neat sketch of the assembly indicating the important dimensions.

- Q.2** (a) What do you understand by self locking of brake? Explain self locking condition of block brake with suitable diagrams. **03**
- (b) How do you determine life of mechanical component which is subjected to different stress levels for different parts of work cycle? **04**
- (c) A double shoe brake is shown in following figure. The brake drum rotates in anticlockwise sense at 720 rpm, when the actuating force of 2.4 kN is applied. The coefficient of friction between the blocks and drum is 0.25. Determine the braking torque and the amount of heat generated. **07**

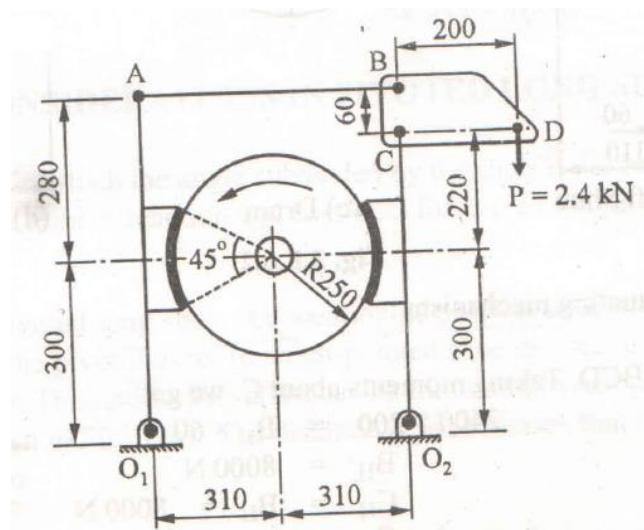

OR

- (c) A differential band brake is shown in following figure. The angle of contact is 280 deg. The brake is sustain a torque of 400 Nm. The band has compressed woven lining and presses against cast iron drum of 0.375 m diameter. Assuming coefficient of friction as 0.3:
1. Determine the necessary operating force P.
 2. Find the width of steel band for thickness of 2 mm, assuming safe stress in tension as 55 N/mm².
 3. Find the section of the brake lever.

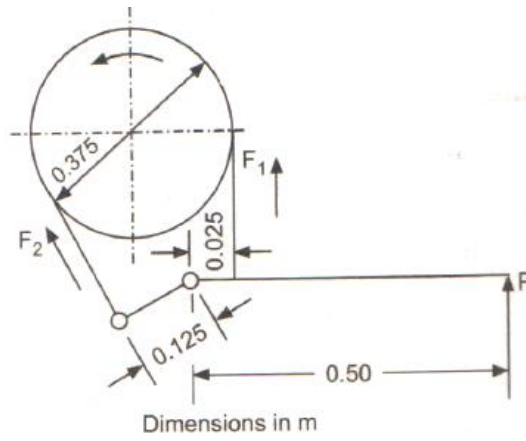

- Q.3** (a) Explain Goodman and modified Goodman diagrams for bending stresses. **03**
- (b) A mine hoist employs 6×37 wire rope and has 6 falls of the rope. The maximum lifting capacity is 25 kN. The maximum velocity of 2 m/s is attained by the hoist trolley within 1.5 seconds. The dead weight accounts for 10% of the service load. Overall efficiency of mine hoist is 95%. Design the rope for above application using following data: **04**
- Breaking load = $470d^2$ N, wire diameter = $0.045d$ mm, effective area of rope = $0.4d^2$ mm², minimum shaeve diameter = $25d$ mm, factor of safety = 5 and $E = 8 \times 10^4$ MPa. Where, d = diameter of rope in mm.
- (c) 1. A section of C clamp is shown in following figure. Determine force P which can be exerted by the screw if the maximum tensile stress in clamp is not to exceed 140 N/mm². Dimensions in figure are in mm. **05**

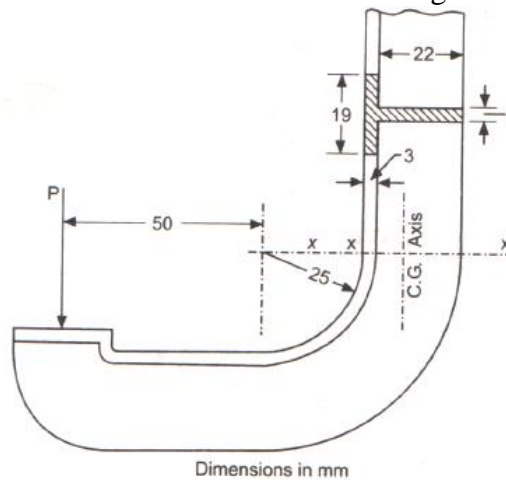

$$R_n = \frac{(B-a) \cdot t + a \cdot h}{(B-a) \cdot \log e \frac{R_i + t}{R_i} + a \cdot \log e \frac{R_o}{R_i}}$$

2. Differentiate straight beam and curved beam. **02**

OR

- Q:3** (a) Explain different loads and stresses induce in wire rope of hoisting mechanism. **03**
- (b) Explain different design steps to design hook for crane. **04**
- (c) Discuss various design steps for cross bar, pins and side links (hook supports) of hoisting mechanism. **07**
- Q:4** (a) 1. What is hydrodynamic lubrication? **02**
2. What is hydrostatic lubrication? **01**

- (b) Discuss the procedure used in designing cast iron pulley. **04**
- (c) A cantilever beam of circular cross section, made of cold drawn steel having an ultimate tensile strength of 500 N/mm^2 and yield strength of 350 N/mm^2 is fixed on one end as shown in following figure. The theoretical stress concentration factor may be assumed as 1.42 and the notch sensitivity is 0.8. Assume surface factor as 0.85 and size factor as 0.855. Determine life of the cantilever beam, if factor of safety is 1.5 and reliability is 50%. **07**

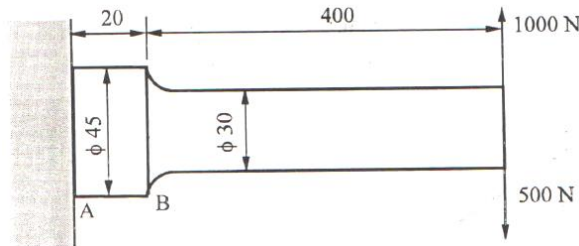

OR

- Q:4** (a) What are four objectives of lubricants? **03**
- (b) Explain design for finite and infinite life of mechanical component under complete reverse stress. **04**
- (c) Following data are relate to full hydrodynamic bearing: **07**
- Radial load = 3.2 kN
 Journal speed = 1490 rpm
 Journal diameter = 50 mm
 Bearing length = 50 mm
 Radial clearance = 0.05 mm
 Viscosity of lubricant = 25 cP
- Assuming that the total heat generated in the bearing is carried by the total oil flow in the bearing, calculate:
1. Coefficient of friction
 2. Power lost in friction
 3. Minimum oil film thickness
 4. Flow requirement in liters/min
 5. Temperature rise

- Q:5** (a) Derive the expression for beam strength of gear tooth. **03**
- (b) Discuss various gear tooth failure modes. **04**
- (c) A 60 mm diameter shaft of a machine operates continuously for 8 hrs daily. The shaft bearing will be subjected to a varying load and speed cycle as follows: **07**

Fraction of cycle	Type of load	Radial load (kN)	Thrust load (kN)	Speed (rpm)
0.1	Steady	4	2	1000
0.1	Light Shocks	2	2	1500
0.5	Light Shocks	5	2	1200
0.3	Steady	2.5	2	1500

The shock factors for ball bearing : Steady load = 1, Light shock = 1.5.
 The details of ball bearing are : Bearing number 6412, $C_0 = 69500 \text{ N}$, $C = 83000 \text{ N}$. Determine life of bearing.

F_a/C_0	$F_a/F_r > e$		e	$F_a/F_r \leq e$	
	X	Y		X	Y

0.014	0.56	2.3	0.19	1	2.3
0.028	0.56	1.99	0.22	1	1.99
0.056	0.56	1.71	0.26	1	1.71

OR

- Q.5 (a)** What do you understand by static load carrying and dynamic load carrying capacity of ball bearing? Explain the criterion for static load carrying capacity and dynamic load carrying capacity of ball bearing. **03**
- (b)** Following data is given for a steel spur gear transmitting 7.5 kW power running at 1440 rpm to a machine running at 480 rpm. Approximate center distance = 240 mm, Allowable bending stress for pinion and gear are 200 MPa and 160MPa respectively. Surface hardness is 450 BHN. Tooth system is 20° full depths involutes. Suggest size of the pinion and gear for this application. **04**
- (c)** Design gear pair for above application. **07**

$$Y_p = 0.154 - \frac{0.912}{Z_p} \text{ (full depth)}$$

$$Y_p = 0.175 - \frac{0.841}{Z_p} \text{ (stub gear)}$$

$$F_s = f_b \times b \times Y_p \times \pi \times m$$

$$C = 11860 \times e$$

$$e = 0.025$$

$$F_d = F_t + \frac{21v(cb + F_t)}{21v + (cb + F_t)^{1/2}}$$

$$Q = \frac{2Z_g}{Z_g + Z_p}$$

$$k = \frac{f_{es}^2 \sin \phi}{1.4} \left[\frac{1}{E_p} + \frac{1}{E_g} \right]$$

$$f_{es} = 2.7459 \times \text{BHN} - 68.65 \text{ MPa}$$

$$F_w = D_p \times Q \times k \times b$$
